

Original Operating Instructions

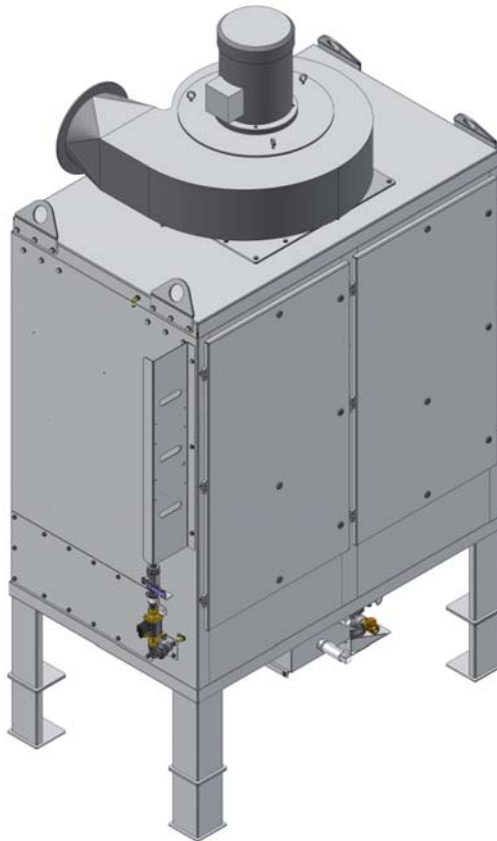

Fig.:Collector with pump and top mount fan

Collector EM-Profi

Date: 07.01.2015
Version: 2015.1
Language: English

Contents

1	General information	4
2	General safety information	6
	2.1. General safety information	6
	2.2. Warnings.....	7
	2.3. Signal words.....	7
	2.4. Measures to be taken by the user/operator	8
	2.5. Residual risks	9
3	Intended use	10
	3.1. Intended use	10
	3.2. Improper use	10
4	Construction	11
5	Function	12
6	Delivery, transport and storage	13
	6.1. Delivery	13
	6.2. Transport	13
	6.3. Storage.....	13
7	Assembly	14
	7.1. Assembly.....	14
	7.2. Outdoor installation	14
	7.3. Dimensions	14
	7.4. Cooling lubricant recirculation	14
8	Installation / fan construction.....	15
	8.1. Commissioning	15
	8.2. Shut down.....	15
	8.3. Startup of fans	15
9	Startup	16
	9.1. Commissioning (Checklist).....	16
	9.2. Testing	17
10	Operation	18
	10.1. Differential pressure monitoring filter elements	18
	10.2. Demister flush interval	18
11	Maintenance	19
	11.1. Maintenance.....	19
	11.2. Maintenance checklist.....	20
	11.3. Removal of filter elements	21
	11.4. Removal of the lower filter level	21
	11.5. Removal of the upper filter level.....	22
	11.6. Cleaning the filter elements	23
	11.7. Cleaning agent	23
	11.8. Ultrasonic cleaning bath	23

11.9.	Drying of the filter elements	23
11.10.	Installation of the cleaned/new fine filter elements.....	24
11.11.	Installation of the upper filter level.....	24
11.12.	Installation of the lower filter level	25
12	Malfunction.....	26

1 General information

Information on the Operating Instructions

These Operating Instructions comprise important information on the operation of the collector and must be read completely and carefully before starting any work on the separator.

These Operating Instructions are an integral part of the product and must be kept available for the personnel at all times in the direct vicinity of the separator.

Compliance with all specified safety information and process instructions is the prerequisite for safe operation.

Furthermore, the local accident prevention regulations, safety information, and country-specific standards as well as the generally recognized standards of good practice applicable at the place of operation of the suspended particles filter must be complied with.

Spare and wear parts

Spare and wear parts

When changing spare and wear parts, only use spares approved by Camfil APC.

Installation of non-approved parts will jeopardize the operational safety of the separator and void the warranty.

Camfil APC assumes no liability for damage attributable to the use of non-approved spare and wear parts.

Glossary

Exhaust air operation

The cleaned air is discharged to atmosphere after filtration.

Mist

Mixture of solid or liquid floating particles and air.

Emulsion

Finely distributed mixture of two different (normally non-miscible) liquids without visible separation (E.g. mixing ratio of cooling lubricant/water < 15%).

Cooling lubricant (CL)

Cooling lubricants are used to dissipate heat and reduce the friction between the tool and the work piece.

Clean air recirculation

The cleaned air is recirculated to the workspace after filtration.

2 General safety information

2.1 General safety information

This chapter comprises general safety information that must be observed and complied with during transport, installation, commissioning, operation, maintenance and disposal.

Non-observance of/non-compliance with the general safety information causes hazards for the operators, the environment, and the system.

In addition to the Operating Instructions, the mandatory regulations on accident prevention and environmental protection as well as the generally recognized technical rules for safe and professional working processes applicable in the country of use and at the site of installation must be observed and complied with.

Note *In addition to this information, any further general safety and accident prevention regulations must be observed.*

The collector is designed for installation in heated buildings. The temperature in the room should not fall below a minimum of +40°F.

The collector is provided in accordance with state-of-the-art technology at the time of delivery and is considered generally safe to operate.

The collector may pose hazards for persons, the separator itself, and for other assets of the operating company if non-qualified personnel work on and with the collector or if the collector is used improperly.

Only operate the collector in its fully functional state.

Any retrofits, amendments or conversions of the collector are generally prohibited. Always consult with Camfil APC before attempting any such measures.

2.2. Warnings

Warnings are marked with a signal word and a symbol for the respective danger.

Warnings are preceded by signal words describing the extent of the hazard.

An additional hazard-specific symbol warns against a potential risk for people.

The warnings are structured as follows:



Type of danger, and source of danger

Potential consequences of non-compliance

- Avoidance: measures / prohibitions
-

2.3. Signal words

Warnings are characterized by one of the following signal words.

- **Danger**
- **Warning**
- **Caution**



Stands for an **immediate danger**

If it is not avoided, the consequences are death or extremely severe, crippling injuries.



Stands for a **pending danger**

If it is not avoided, the potential consequences are death or extremely severe injuries.



Stands for a **potentially hazardous situation**

If it is not avoided, the potential consequences are slight or minor injuries.



Stands for a **potentially damaging situation**

If it is not avoided, the product or objects in its vicinity may be damaged.



Ensure the perfect condition of the separator

Information on source, type, and prevention of a hazard

These warnings comprise information about the source and type of a hazard, and instructions about how to prevent the hazard.

Example:

High center of gravity!

Risk of injury by system tipping over.

- Always attach the hoisting gear in the eyelets at the top only.
 - In case of transport with fork lift/lifting truck:
Carefully transport the separator upright on a pallet.
-

Conditions for safe operation

- Only operate the collector in fully functional state.
- Install the collector in accordance with the installation plan and the installation conditions.
- The cleanliness and clear arrangement of the workstation at the system must be ensured.
- The user must ensure sufficient fresh air supply in the work-rooms.
- Malfunctions occurring at the collector must be remedied immediately.

2.4. Measures to be taken by the user/operator

Personnel training

Personnel must be instructed in regular intervals about the potential residual risks and how to act in case of malfunctions.

Personnel qualification

Only qualified personnel are allowed to work on the collector. The following measures must be taken before allowing personnel to start working on the system:

- Instruction about hazards that may arise.
- Clear definition of the responsibilities for operation, maintenance and repair to avoid any doubts about competences about safety-relevant aspects.
- Before starting to work on the collector, the operators must read the technical documentation of the system.
We recommend that the operating company have the operators declare in writing that they have read and understood the technical documentation.

Comply with the proper shutdown procedures

For any work relating to the transport, installation, commissioning, use, operation, maintenance, and repair, the system must be switched off via the main switch; then, the main switch must be locked out and tagged out.

2.5. Residual risks

The risk overview indicates the potential residual hazards when working on and with the collector.

Type of hazard	Danger spot	DANGER	Measure
Danger zone 1	Collector		
<i>Mechanical hazard</i>			
Tipping	Installation	Risk of injury	Installation on appropriate foundation only.
Crushing	Maintenance door	Risk of injury	Open door when system is at standstill only.
Heavy lifting	Maintenance door	Risk of injury	Use crane for heavy components

3 Intended use

3.1. Intended use

The collector is suitable exclusively for the extraction and separation of non-corrosive emulsion mist (water-soluble cooling lubricant mists with a water ratio greater than 85%).

 **DANGER**

Extraction of potentially explosive gases, vapors and mists

Very severe or fatal injuries by fire in/explosion of the system.

- Do NOT extract potentially explosive gases, vapors and mists.

 **DANGER**

Installation of the collector in potentially explosive areas

Very severe or fatal injuries by fire in/explosion of the system.

- Do NOT operate the separator in potentially explosive areas.

NOTICE

Extraction of corrosive media

Corrosion damage in the separator.

- Do NOT extract any corrosive media.

Camfil APC assumes no liability for improper use!

3.2. Improper use

The collector must not be used for the extraction and separation of potentially explosive gases, vapors and mists.

Furthermore, the following constitutes improper use:

- Arbitrary modification or retrofit of the collector by the operating company or the operators.
- Any type of operation that might affect safety.

4 Construction

The EM-Profi is designed as oil-tight modular welded construction.

Individual modules are assembled in order in a variety of combinations.

The core is made of the middle modules containing the integrated filter elements. In addition, a HEPA filter level can be fitted.

Various bases including siphon, outflow pump back station, etc. may be chosen for the extraction of the coolant.

Likewise options for the fan include integrated fan or top mount fan.

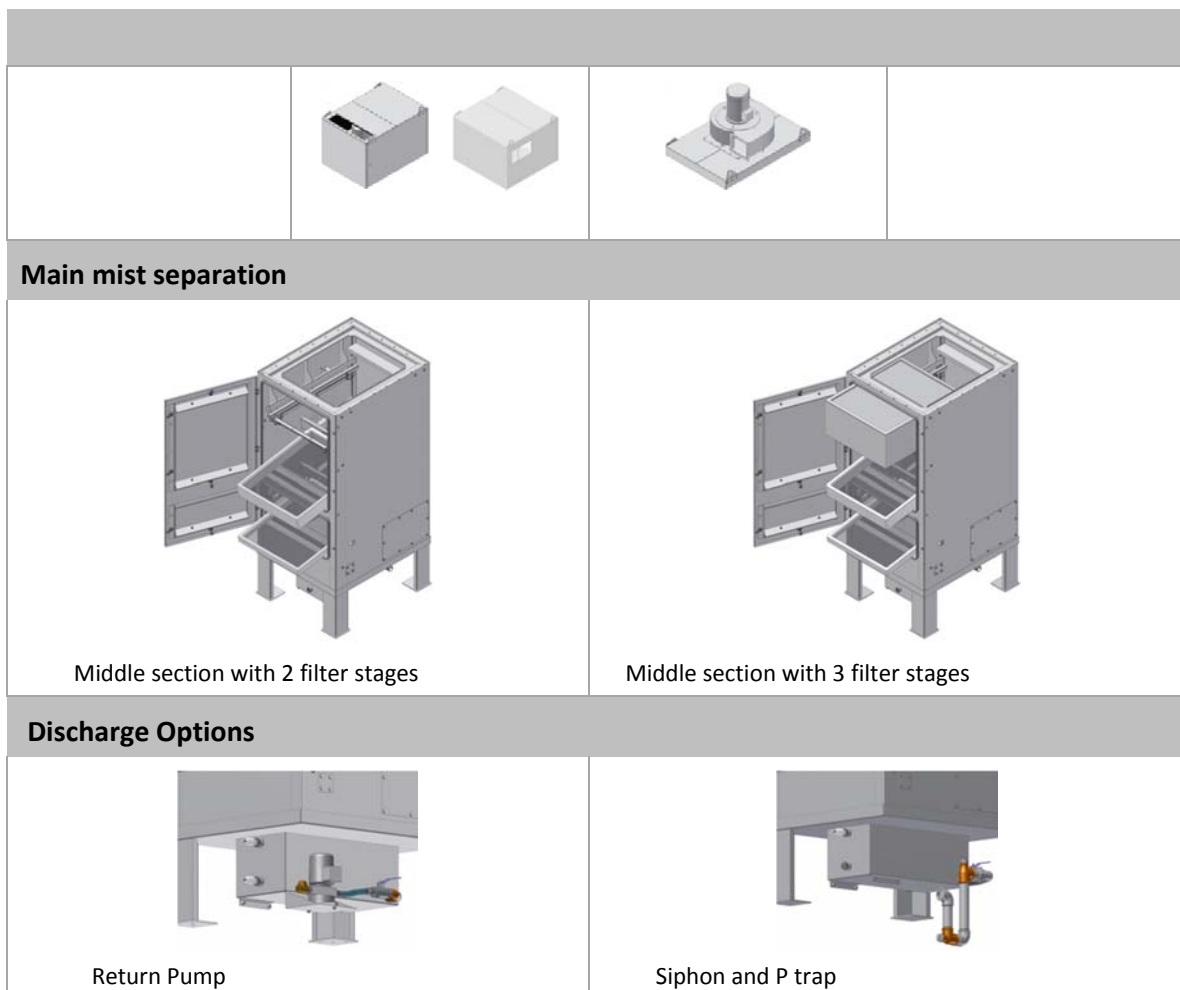

5 Function

AIR INTAKE

The oil contaminated air passes laterally below the separator.

FILTRATION

separation of the emulsion mists takes place through highly efficient demister filter stages connected in series.

The separation of the demister filter stages in this case increases progressively. The demister filter stages can be expanded with a subsequent filter level.

The effect of the separation is based on the principle of inertia, blocking effect, diffusion and coalescence.

In addition, a self cleaning effect is achieved through appropriate material selection and mounting position of the demister filter stages. As a result, a high operational safety and availability is guaranteed.

Optionally, a patented cleaning equipment for the first level of the demister filter can be installed.

COOLING LUBRICANT FLOW

Deposited oil collects in the discharge and flows, depending on the sub-module, either via a siphon or is pumped by recirculation pump for recycling.

The cleaned air is recirculated into the work area (clean air recirculation).

AIR OUTLET

Option for integrated or top mount fan.

6 Delivery, transport and storage

6.1. Delivery

Delivery condition

The collector is delivered according to order confirmation.

Scope of delivery

- Check completeness of the shipment by means of the packing sheet and order confirmation.
- Immediately report in writing possible transport damage and/or missing parts.

6.2. Transport



High center of gravity!

Risk of injury by CL mist collector tipping over.

- Attach the hoisting gear in the eyelets at the top only.
 - In case of transport with fork lift/lifting truck:
Carefully transport the separator upright on a pallet.
-

6.3. Storage

- Only store in dry rooms.
- Store CL mist separator in original packing or cover with a suitable protective covering.

7 Assembly

7.1. Assembly

A yellow rectangular box with a black border containing a black triangle with an exclamation mark and the word "CAUTION" in bold black capital letters.

High center of gravity!

Risk of injury from falling separator.

- Hoists hang overhead in the eye bolts.
 - When transporting with a forklift/pallet truck:
Ensure the collector is securely upright on the pallet.
-

7.2. Outdoor installation

The collector is not suitable for outdoor installation.

7.3. Dimensions

See separate data sheet.

7.4. Cooling lubricant recirculation

Continuous emptying of the collector is required for trouble-free operation.

A blue rectangular box with a black border containing the word "NOTE" in white italicized capital letters.

Dispose of oil properly!

We recommend the oil be directly recirculated into the cooling circuit. If this is not possible, the oil must be collected in a separate collection container and disposed of by qualified personnel

8 Installation/fan construction

8.1. Commissioning

Installation is permitted only by a trained electrician. The qualified personnel has to ensure that the fan is in good condition. The commissioning requirements for electrical equipment must be observed.

- Check the safety devices
- Switch on main switch
- Switch on the fan

Only switch on when all ductwork is connected, so that sufficient system resistance is present.

- During commissioning, check the direction of rotation of the motor.

NOTE

The fan must rotate in the direction of the arrow

- Power amp draw. The rated amp draw of the motor must not be exceeded.

8.2. Shut down

- Fan switch off.
- Turn main switch to the "OFF" position and secure it against unauthorised reactivation.

8.3. Startup for direct activation

In the case of the direct start up of the fan (no soft start motor starter), the motor develops a high torque at a high starting current.

The starting current during the startup phase is between 5 and 8 times the nominal current depending on the impeller class.

This high power consumption must be taken into account when choosing the fuses.

9 Startup

The commissioning must be performed by trained personnel.

NOTE

Collector operation without filter elements

Leakage of cooling lubricant mist in the workspace

- Operate collector only with filter elements installed.
-

9.1. Commissioning (Checklist)

Prior to commissioning, the following operations must be done:

- Suction and exhaust air duct installed.
- Installed switchgear.
- Connected electrical load.
- Installed filter elements.
- Maintenance doors closed.
- Seal checked (visual).
- Siphon filled with coolant.
- Direction of fan rotation checked.
- Differential pressure read and recorded.
- Check the fan direction of rotation.
- Check the power consumption of the fan motor.
- Check the setting values of the motor-protective relay.
- Test function of the individual components.
- Balancing duct system. Ensure uniform suction at the individual collection points.
- Switch on the fan.

Initial startup

NOTE

Too many startup cycles per hour

Our motors conform to the class S1 and are designed for continuous operation. Frequent starting can cause overheating of the motor winding.

Therefore we recommend that the fans not be cycled on/off more than two times per shift.

9.2. Testing

Inspection before initial operation	The collector must be inspected for safe operating conditions before first use and after modifications or repairs. At least, it must be checked externally for visible damage or defects
Regular examination	Safety devices shall be tested at least annually, and the collector itself shall be tested at least every two years.
Air airflow measurements	The necessary periodic airflow measurements must be carried out by qualified personnel with the necessary expertise.

10 Operation

The coolant collector should be operated only by trained personnel.

NOTE

Collector operation without filter elements

Leakage of cooling lubricant mist in the workspace

- Operate collector only with filter elements installed.
-

10.1. Differential pressure monitoring filter elements

The separator is equipped with a differential pressure indicator. The differential pressure should run at 5" or less.

Demister	5" w.c.	Remove and clean demister or replace it with new
----------	---------	--

10.2. Demister flush interval

Pause time: 2-3 hrs

Wash cycle time: 30 s

Cycle time: 30-second spray on timer. Time between cycles can be set at 120 to 180 minutes.

11 Maintenance

11.1. Maintenance

Maintenance work may only be performed by trained personnel.

Only carry out servicing, dismantling, cleaning and replacement of parts when system is switched off.

Switch off and secure separator to prevent unexpected operation.

Ignition hazards are to be avoided when cleaning.

The necessary personal protective equipment (E.g. safety shoes, protective gloves, safety goggles, etc.) must be worn!

Dirt deposits/deposits

Deposits should be removed upon discovery, as they are very difficult to eliminate once encrusted.

Environment cleaning

Cleaning of the separator, such as floor, walls, ceiling and various surfaces and connected piping should be conducted when necessary.

Log book

Cleaning and maintenance operations should be recorded in a log book.

Maintenance contract

Upon request, you may take out a maintenance contract with Camfil APC.

11.2. Maintenance checklist

Maintenance point	Interval	Maintenance note
Filter elements	--	Differential pressure reading: If differential pressure 5" w.c.: Clean or change filter elements.
Drain trough/return siphon	500 Hours	Clean trough Clean siphon. Fill the trap with treated coolant.
Separator	500 Hours	Visual inspection: Check the interior for dirt. If there are heavy deposits, check filter elements for correct attachment and possible damage. Clean housing if necessary.
Jets	500 Hours	Check the condition of the nozzles, clean if necessary. Replace defective nozzles
Gaskets	500 Hours	Visual inspection: Check flexibility and condition of the gaskets. Replace hard or damaged gaskets.

11.3. Removal of the pre filter

General safety instructions.

Switch the separator off and protect it against re-activation.

Note Deteriorating extraction performance and high Differential pressure indicate plugging of the filter elements.



Contaminated filter elements!

- Wear appropriate personal protective equipment (safety gloves, helmet, goggles, ...).



Pollution of the environment by leaking fluid

Collect the filter elements in a tub to prevent contamination of the environment by leaking fluid.

11.4. Removal of the lower filter level

► Press tensioning bracket

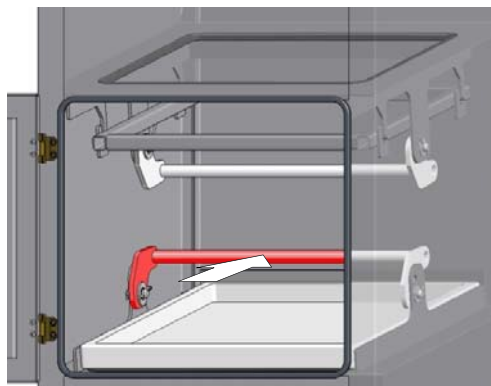

► Pull out filter element

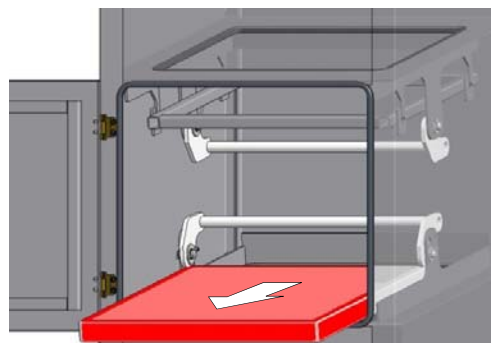

11.5. Removal of the upper filter level

- ▶ Press tensioning bracket

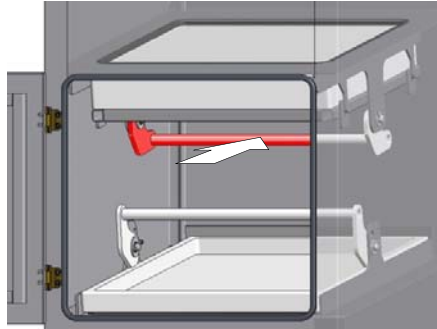

- ▶ Pull out filter element

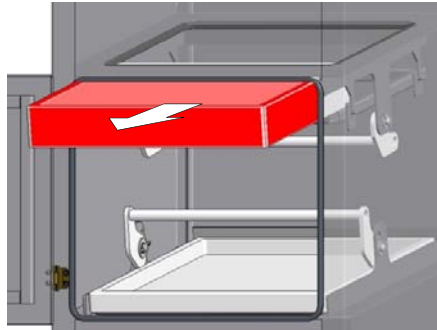



11.6. Cleaning the filter elements

Contaminated filter element!

- Wear appropriate personal protective equipment (safety gloves, helmet, goggles, ...).

11.7. Cleaning agent

Note The cleaning agent must be able to dissolve greases and oils and remove scaling.

- Use suitable cleaning agents.

11.8. Ultrasonic cleaning bath

- Clean filter elements for at least one hour in an ultrasonic cleaning bath with grate insert (bath temperature ca. 115 °F ... 150 °F) with the addition of a suitable cleaning agent.
- Always keep the cleaning bath moving to rinse off dissolved dirt.
- Rinse loosened soil matter out of the filter element with a clean stream of water
- Dispose of cleaning liquid in conformity with the legal regulations.



Beware of excessive water pressure!

Risk of damage to filter elements.

Water pressure <60 PSI; maintain a spraying distance of approx. 1 ft.

11.9. Drying of the filter elements

- Place filter elements inclined to let them drip off.
- Turn filter elements every hour.

Drying period approx. 5 hrs

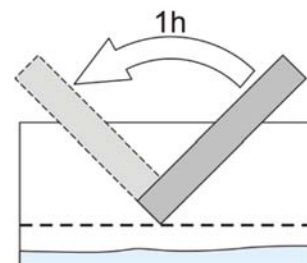

11.10. Installation of the cleaned/new fine filter elements

NOTICE

Wet filter elements!

Use only dry filter elements.

Mounting position

Arrows point upwards.

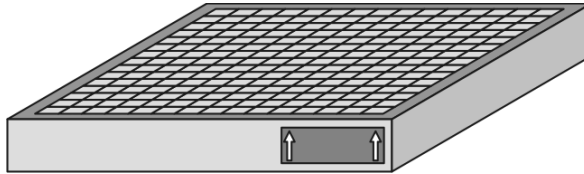

A label with Art. No., filter element size, and two position arrows is attached at the front of the filter element.

11.11. Installation of the upper filter level

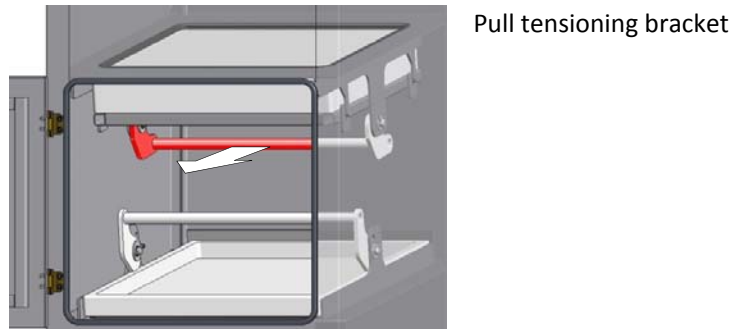
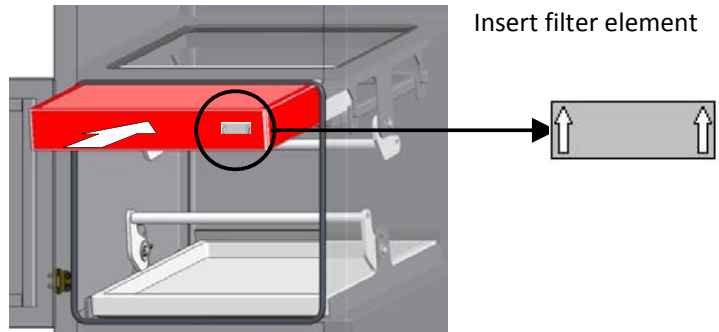

11.12. Installation of the lower filter level

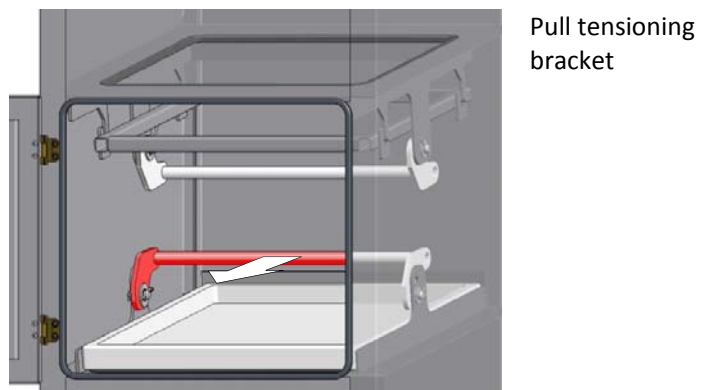
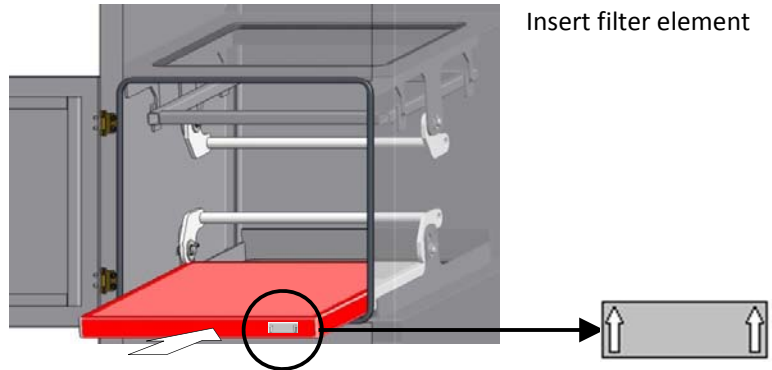

Close the maintenance door

12 Malfunction

Safety shutdown

Connect a lockable EMERGENCY STOP switch upstream of the system to prevent inadvertent activation of the system in case of malfunctions during repairs.

Problem	Possible Cause	Action
Insufficient suction power	Improper sense of rotation of fan	Change electrical connection (reverse polarity)
	Filter elements clogged	Clean filter elements
	Outlet siphon clogged	Remove clogging
	No liquid in discharge siphon, secondary air is aspirated through siphon	Fill siphon
Differential pressure at 5" w.c.	Filter elements clogged	Clean filter elements. If this does not reduce the resistance, replace the filter elements
By Pass of liquid at the air outlet	Filter element loose/bad or missing gaskets	Check for secure fit, re-tighten clamps
	Filter elements clogged	Clean filter elements

Copyright

This document was written in the the technical documentation of Camfil APC.

All rights to this documentation, especially the rights of reproduction, distribution and translation are the responsibility of Camfil APC, even in the event of industrial property rights.

No part of the documentation may be reproduced in any form or processed using electronic systems, copied or distributed, without the prior written consent of Camfil APC.

© 2014 Camfil APC

Manufacturer and service address

Camfil Air Pollution Control

3505 South Airport Road
Jonesboro, AR 72401

Phone: 870-933-8048

Fax: 870-933-8381

email: filterman@camfil.com

Internet: www.farrapc.com

SERVICE PHONE: 870-933-8048

We reserve the right to make technical changes and deviations from the illustrations and specifications in this guide which are required per order.